



Dolby Atmos[®] for the Home Theater

April 2015

Dolby Atmos[®], the revolutionary cinema sound technology, has come to home theaters. With Dolby Atmos, content creators can precisely place and move sounds anywhere in your living room, including overhead, to make entertainment incredibly immersive and lifelike.

This white paper is designed to explain how Dolby Atmos will work in home theaters and how you can build a Dolby Atmos enabled system or upgrade your existing system to support Dolby Atmos. This paper also explains the technological components of Dolby Atmos in home theater and the tools that content creators and broadcasters will use to create and deliver Dolby Atmos content to homes.

Why replace channel-based surround sound?

Dolby Atmos is a revolutionary technology that moves beyond the paradigm of channel-based audio, which has gone as far as it can in the home.

Dolby has led home theater technology since the late 1980s, when we introduced four-channel Dolby[®] Pro Logic[®]. We led the development of 5.1 and then introduced 7.1 surround sound in the home and the cinema. But as home theater expanded to 9.1 and even 11.1 systems, the problems of pursuing more and more channels became clear. Home theater content often originates from theatrical content that is mixed, at best, in 7.1 sound and many times in 5.1. That meant that 9.1 or 11.1 systems reached a point of diminishing returns in parsing and upmixing that limited signal to serve more and more channels.

In addition, the ability to recreate reality using channel-based audio is inherently limited. In real life, sounds move in specific and sometimes complicated ways—a hummingbird flies off a tree branch, hovers in front of a pair of blossoms, and then dives down to a fountain for a drink. Simply moving the hummingbird's sound from the Left Height channel to the Right Front channel can't possibly recreate the detail of that bird's flight. And when you lose those details, it detracts from the brain's sense that what it's watching is real.

A cinema solution

Dolby first started investigations into a solution to the problems of channel-based audio in the cinema. Our goal was to free filmmakers from the limitations of audio channels by developing a system that allowed them to determine exactly where a sound should be and where it should move in three dimensions—that is, to faithfully recreate that hummingbird's flight in all its complexity.

We worked closely with filmmakers and sound mixers to perfect the technology. Renting out entire movie theatres to use as laboratories, Dolby engineers worked hand in hand with sound mixers, adapting their inputs into what would ultimately become the tool set that enabled mixers to create compelling Dolby Atmos object-based soundtracks.

The result of that intense collaboration, Dolby Atmos, debuted in June 2012 in the movie *Brave*. Since then, all the major Hollywood movie studios have embraced the technology. In the first two years alone, studios around the world have released more than 230 feature films in Dolby Atmos.

Dolby Atmos and sound objects

Dolby Atmos is based on the concept of sound objects. In the cinema, Dolby Atmos relies on a combination of 9.1 “bed” channels and up to 118 simultaneous sound objects to deliver an enveloping sound scene. Every sound in a scene—a child yelling, a helicopter taking off, a car horn blaring—can be a separate sound object. Each of those sounds comes from a specific location in the scene, and in some cases, they move. The car careens from left to right, while the yelling child runs up a set of stairs.

Using sophisticated content creation tools that represent the sound objects in a three-dimensional space, filmmakers can isolate each of the sound objects in a scene and decide exactly where they want them to be and how they want them to move. In the final sound mix, the sound objects are combined with metadata—additional data that describes a number of parameters about the sound object, including its location and movement, if any.

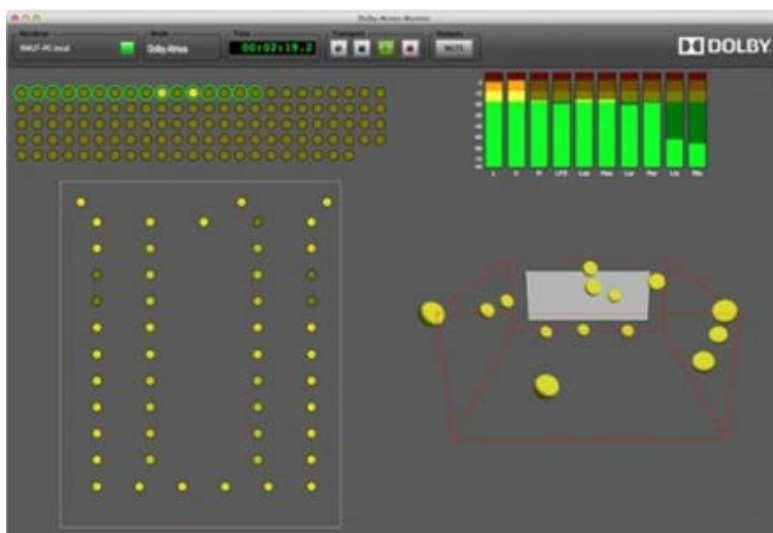

Figure 1: Filmmakers can use this tool to manipulate sound objects in a three-dimensional space.

Dolby Atmos in home theater

Dolby has now developed the technology required to translate the Dolby Atmos experience in cinema to home theaters. In the case of the home theater, every sound in the mix is represented as an audio object. What happens when you play a Dolby Atmos film, whether from a Blu-ray Disc™ or a streaming video service, is quite remarkable. When you set up your Dolby Atmos enabled A/V receiver (AVR), you'll have informed your receiver how many speakers you have, what type of speakers they are (large, small, overhead, and/or Dolby Atmos enabled), and where they're located. Your receiver will decide—in real time—exactly which speakers it needs to use from moment to moment in order to reproduce the sounds of the car careening across the screen and the child fleeing up the stairs. That detailed, very specific movement of sound helps your brain suspend disbelief and feel as if what you're watching is real.

The flexibility of Dolby Atmos object-based sound makes it incredibly adaptable. A Dolby Atmos movie can be played back on nearly any speaker configuration in the home. You'll be able to hear the placement and movement of sound in a Dolby Atmos movie whether you have a system with five speakers on the floor and two overhead, or 24 speakers on the floor and 10 overhead (the current maximum for a Dolby Atmos supersystem). The more speakers you have, the more precise the audio positioning becomes.

And you have lots of flexibility to upgrade your system. If you add more speakers, your AVR can use them to provide you with even more detailed, richer sound.

Delivery of Dolby Atmos movies

Major Hollywood studios are partnering with Dolby to create Dolby Atmos home video versions of current box office releases and previously released favorites. In addition to global studio partnerships, Dolby is partnering with game, music, and broadcast content creators to take advantage of Dolby Atmos technology for future home theater use.

We wanted to ensure that entertainment fans could get Dolby Atmos movies in the same ways they get movies now, on Blu-ray Disc or through streaming video services.

We invented a new, scalable algorithm as well as new extensions for our existing technologies, Dolby TrueHD, which is Dolby's lossless Blu-ray™ format, and Dolby Digital Plus™, which is used by leading streaming video providers and for secondary languages on

Blu-ray Disc. Both formats now support Dolby Atmos sound, meaning that you'll be able to play Dolby Atmos movies from your Blu-ray player or streaming device.

A Blu-ray player that fully conforms to the Blu-ray specification can play a Dolby Atmos movie without a firmware update. The player will need to be connected to an AVR capable of supporting Dolby Atmos and set to audio bitstream out. Note that some Blu-ray players default to secondary audio, a playback mode in which third-party content is mixed with the primary soundtrack and output as a Dolby Digital signal; be sure to turn this feature off to ensure decoding and playback of Dolby Atmos content by your AVR.

There's also no need to buy new HDMI[®] cables. The current HDMI spec (v1.4 and later) fully supports Dolby Atmos audio.

Dolby Atmos audio tracks (both Dolby TrueHD and Dolby Digital Plus) are backward compatible. If you play a movie mixed in Dolby Atmos on a non Dolby Atmos system, you'll experience traditional 5.1 or 7.1 audio, depending on the layout of your system. This means content providers don't need to maintain separate Dolby Atmos and non Dolby Atmos mixes.

Setting up your Dolby Atmos home theater

Although Dolby Atmos is a revolutionary new home theater format, it doesn't require that you start from scratch. Although you will need a new AVR, in most cases, you'll be able to keep most, if not all, of your existing speakers.

Many people now have 5.1 or 7.1 systems with a subwoofer and either five or seven speakers positioned at about ear level. Many of these speakers will work without a problem in a Dolby Atmos system.

The importance of overhead sound

In real life, sounds come from all around us, including overhead. Having the ability to recreate overhead sounds is a key element in making Dolby Atmos sound so realistic. If we see a helicopter take off onscreen and then hear its blades cutting through the air above our heads, the experience makes us feel like we're really in the scene, not just watching it.

Dolby Atmos cinemas recreate these overhead sounds with an array of overhead speakers above the audience. Some home theater enthusiasts will also be able to install speakers in or on their ceilings, but you don't have to.

Through our knowledge of psychoacoustics and sound physics, we've developed Dolby Atmos enabled speakers that can create overhead sound even though they're only a few feet off the floor. These speakers fire sound upward, where it reflects off the ceiling to produce an incredibly lifelike re-creation of overhead sound—you really have to hear them to believe them.

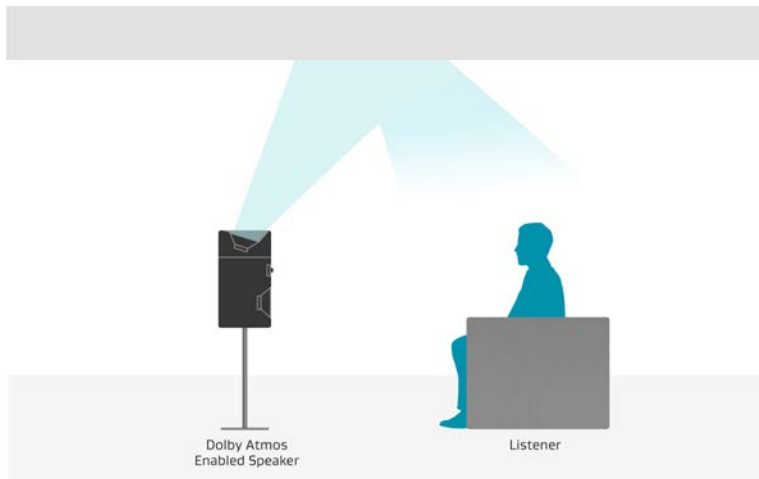

Figure 2: Dolby Atmos enabled speakers reflect sound off the ceiling to produce an incredibly lifelike re-creation of overhead sound.

You will be able to purchase units that include both traditional front-firing speakers and upward-firing elements in one cabinet. (These speakers have two sets of posts, one for the traditional speaker and one for the upward-firing Dolby Atmos enabled speaker.) The Dolby Atmos drivers are enclosed in a sealed baffle and integrated in the primary speaker cabinet.

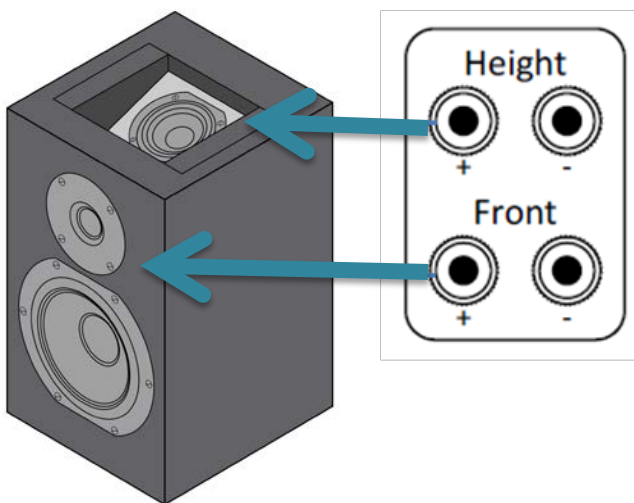

Figure 3: Integrated Dolby Atmos enabled speakers include both traditional drivers and upward-firing elements in the same cabinet. The two sets of speakers have individual posts.

But if you already have conventional speakers you like, you can simply buy Dolby Atmos enabled add-on speaker modules. These include only the upward-firing elements. You can place these add-on modules on top of your current speakers or on a nearby surface.

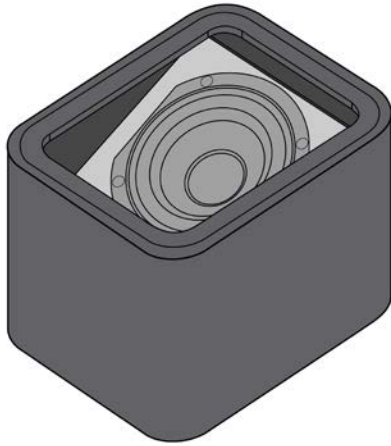

Figure 4: You can place Dolby Atmos enabled add-on speaker modules on top of or near your existing traditional speakers.

Dolby Atmos enabled speakers can produce an incredibly accurate Dolby Atmos experience in many types of rooms. You'll get the best sound if your ceiling is flat (not vaulted or angled) and made of an acoustically reflective material, such as drywall, plaster, concrete, or wood. Testing by Dolby suggests that the user can achieve a high-quality overhead experience from Dolby Atmos enabled speakers in environments where the ceiling height ranges from 7 to 14 feet (2.3 to 4.26 meters).

In fact, the system is so robust that recessed lighting fixtures, chandeliers, crown molding, and heating or air conditioning vents in your ceiling do not noticeably interfere with the Dolby Atmos experience.

When to avoid overhead speakers

There are some rooms in which we don't recommend using overhead speakers. If your ceiling is low or you have to mount your loudspeakers on overhead trusses or brackets, the overhead speakers will be closer to the listening position. The audio may be distracting because you'll hear exactly which speaker is producing the sound instead of feeling immersed in an atmosphere in which sounds occur naturally overhead.

In this environment, Dolby Atmos enabled speakers may better reproduce the Dolby Atmos sound you would hear in a movie theatre, where the overhead speakers are high in the

auditorium, creating a more diffuse experience. Audio experts who have heard Dolby Atmos enabled speakers agree that in certain rooms, the sound these speakers produce can be preferable to the sound that overhead speakers produce.

Speaker recommendations

Dolby recommends that you use four Dolby Atmos enabled speakers when possible. Use of four speakers will make the placement of overhead sounds more accurate, and you'll get more precise, realistic sounds as an object—such as a helicopter—passes overhead in a video. Two of the speakers (whether they are integrated speakers or add-on modules) should be in the front left and front right speaker locations of your system. The other two should be positioned in the surround sound speaker locations, ideally the rear surround speakers, if you have them.

If you opt to use only two Dolby Atmos enabled speakers, you'll still get a very immersive experience, with sounds moving overhead. Simply place the Dolby Atmos enabled speakers at the front left and front right speaker locations.

For the best sound, place your speakers at or slightly above the height of your ears when you're seated. Avoid placing the Dolby Atmos enabled speakers higher than one-half the height of your wall. Make sure the speakers are at least 3 feet (0.9 meter) away from you, ideally 5 feet (1.5 meters) or more. If you're using add-on modules, place them either on top of your front and surround (ideally, rear surround) speakers or within 3 feet (0.9 meter) of those speakers.

If you use overhead speakers, Dolby recommends that you use four or more speakers when possible, though two speakers will still provide a great experience. If you use four overhead speakers, you should place the front pair of overhead speakers in front of the position where you'll be listening and the second pair of overhead speakers behind you when you're seated. If you use two overhead speakers, mount them slightly in front of where you'll be listening. The ideal overhead speaker should be timbre matched to your primary speakers and support equal power-handling capabilities and full-range performance.

We recommend using overhead speakers with wide dispersion patterns. If you use overhead speakers with narrow dispersion (less than 90 degrees by 90 degrees) or those with aimable drivers, angle the drivers slightly toward your listening position.



Figure 5: If you use overhead speakers, Dolby recommends using four or more.

You can also combine Dolby Atmos enabled speakers with overhead speakers in your home theater. This can be useful if, for instance, you have two speakers already installed in your ceiling but want to add two more speakers that can produce overhead sound. You can add two Dolby Atmos enabled speakers and get detailed overhead sound without going to the trouble of installing new speakers in your ceiling. You'll hear the same overhead sounds whether you're using overhead speakers, Dolby Atmos enabled speakers, or a combination of both.

While the arrangements recommended here will yield the best experience, a Dolby Atmos system can support many other configurations that you may already have in your home. For instance, Dolby Atmos supports the standard "wide" speaker positions on the floor and the front vertical height positions usually found on the top of the front wall, as well as many other speaker positions.

However, before designing your room layout, refer to your AVR's documentation to ensure that it supports the combination of speakers you plan to use.

Describing your new Dolby Atmos system

With the debut of Dolby Atmos, there is a new way to refer to surround sound speaker configurations. It is based on the standard nomenclature (stereo, 5.1, and 7.1) but adds a

number at the end to specify the number of overhead or Dolby Atmos enabled speakers you use (for example, 7.1.4).

The following figures show the most common speaker layouts in a Dolby Atmos system for home theater.

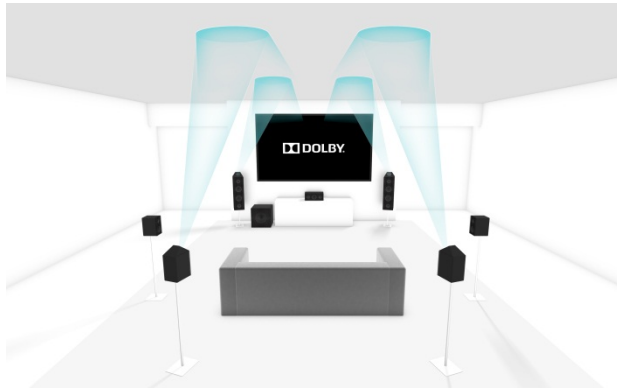

Figure 6: A traditional 7.1 speaker layout with four Dolby Atmos enabled speakers (7.1.4).



Figure 7: A traditional 5.1 speaker layout with four Dolby Atmos enabled speakers (5.1.4).



Figure 8: A traditional 5.1 speaker layout with two Dolby Atmos enabled speakers (5.1.2).

There is one important consideration in expanding your system: new speakers must be added to your Dolby Atmos system in pairs. A new speaker on the right side of the room must be matched by a similar speaker on the left side of the room. This is true for speakers located on the floor as well as overhead. This pairing ensures a balanced soundstage. The exceptions to this rule are when you add speakers in the center or center back locations.

For high-end home theaters, a 7.1.4 system (a traditional 7.1-channel-based layout with four overhead or Dolby Atmos enabled speakers) will provide a great listening experience. If you're ambitious, though, Dolby Atmos can support home theater systems with up to 34 speakers in a 24.1.10 configuration: 24 speakers on the floor and 10 overhead speakers.

Importantly, Dolby Atmos content is not tied to any specific playback configuration. Whether you have a full 7.1.4 system, a 5.1.2 system, or an ultimate 24.1.10 Dolby Atmos system, your receiver will get the same content and play it back in a way that takes full advantage of your specific setup.

As a starting point, we recommend that any system include speakers in the positions normally designated for a 5.1 system. This allows you to play legacy, channel-based content as well as Dolby Atmos content.

Making the right connections

Once you have your speakers set up and you've purchased a new AVR, it's time to hook up your new Dolby Atmos system. Many AVRs that support Dolby Atmos have speaker connections labeled HEIGHT. (Some AVRs do not use that label, but they allow you to assign terminals for the height outputs.) Connect your Dolby Atmos enabled speakers or overhead speakers to those outputs. If you're using four Dolby Atmos enabled speakers or overhead speakers (or think you might in the future), you need an AVR with four height outputs.

Of course, not all the content you play on your home theater will be in Dolby Atmos. The good news is that a Dolby Atmos home theater can play any channel-based content. You can choose to have Dolby surround technology automatically adapt that channel-based signal to use the full capabilities of your new system, including your overhead speakers, thus ensuring that you hear realistic and immersive sound.

If you're not able to upgrade your home theater to Dolby Atmos yet, we still recommend that you purchase the Dolby Atmos version of content whenever that is available. The Dolby

Atmos format was designed to be backward compatible, so it will play on both new and existing hardware platforms. In the future, upgrading your equipment to products capable of supporting Dolby Atmos will unlock the ultimate experience from Dolby Atmos content. In the meantime, you will get a great surround experience from traditional channel-based home theaters.

The technological building blocks of Dolby Atmos

Initially, you'll be able to play Dolby Atmos content from a Blu-ray Disc or from a streaming video service. Eventually, cable, terrestrial, and digital broadcast systems as well as video game consoles will be capable of providing Dolby Atmos content.

To support the transport of Dolby Atmos content, we've updated and improved many of the underlying Dolby technologies already in use today, including Dolby TrueHD, Dolby Digital Plus, and Dolby Metadata-Enhanced Audio Transmission (MAT), while maintaining their full compatibility with older content formats.

The key to creating Dolby Atmos sound is the ability not only to recreate a movie's sound—such as the whine of an ambulance siren—but also to place that siren's whine in a specific place and recreate its movement through space as intended by the audio mixer. All Dolby Atmos content includes both sounds and metadata that describe how those sounds move through the multidimensional sound space.

The Dolby Atmos object audio renderer is the intelligence that directs the system. It determines—on the fly—how to use your speakers to place and move sounds in exactly the way the filmmaker intended.

The Dolby surround upmixer allows you, if you wish, to play channel-based content while making full use of your Dolby Atmos home theater, including overhead or Dolby Atmos enabled speakers.

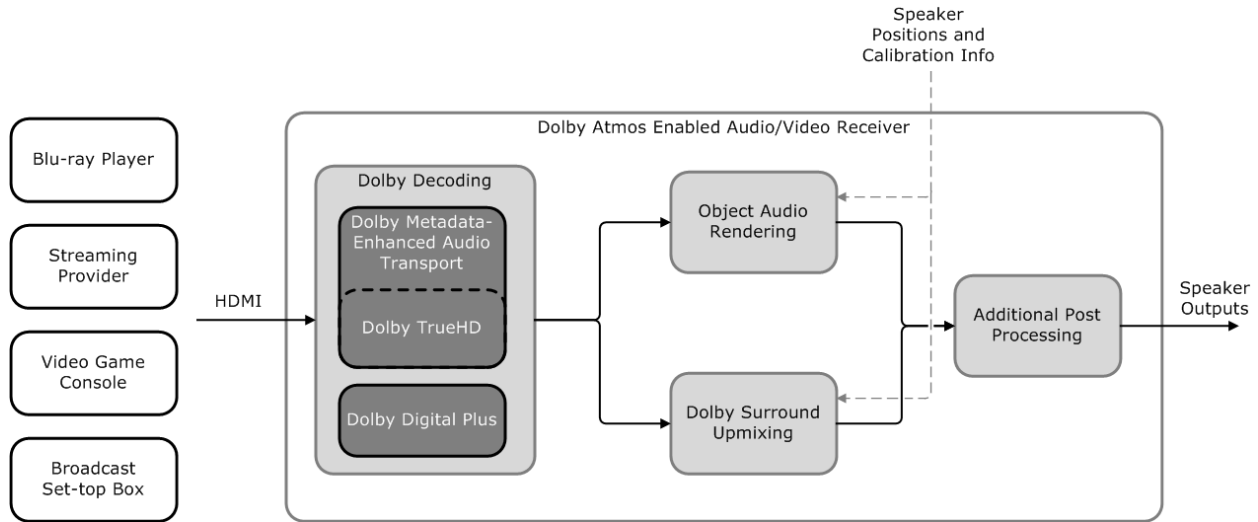

Figure 9: This diagram shows the workflow for translating cinematic Dolby Atmos content to home theaters.

Dolby Atmos in Dolby TrueHD

Dolby has expanded the Dolby TrueHD format, used in Blu-ray discs, to allow the format to support Dolby Atmos content. Before Dolby Atmos, Dolby TrueHD provided lossless support for channel-based audio, such as 5.1 and 7.1. We have added a fourth substream for Dolby Atmos sound. This substream represents a losslessly encoded, fully object-based mix.

Dolby Atmos in Dolby TrueHD is transmitted from a Blu-ray player to your AVR via an HDMI connection. If your AVR supports Dolby Atmos, the Dolby TrueHD object-based audio and related metadata will be decoded, processed, and rendered to your specific speaker configuration.

Dolby Atmos audio can be encoded with Dolby TrueHD at multiple sampling rates (including 48 and 96 kHz) and bit depths (16- and 24-bit). Dolby Atmos enabled receivers will also support legacy Dolby TrueHD bitstreams at multiple sampling rates (including 48, 96, and 192 kHz) and bit depths (16-, 20-, and 24-bit) to provide full backward compatibility with legacy Blu-ray Disc media and Dolby TrueHD music files.

Dolby Atmos in Dolby Digital Plus

The update to Dolby Digital Plus features a new decoder capable of processing content encoded for Dolby Atmos. This module uses new bitstream metadata to extract Dolby Atmos object audio and outputs this information for further processing. The sampling rate for Dolby Atmos content is 48 kHz, the same sample rate as for Dolby Digital Plus content.

Both new audio decoders are designed to be fully backward compatible with legacy channel-based Dolby Digital Plus and Dolby TrueHD soundtracks

Dolby Atmos in Dolby MAT

In the past, the Dolby Metadata-Enhanced Audio Transmission (MAT) encoder resided in a Blu-ray player to pack the variable bit-rate Dolby TrueHD bitstreams for transmission over the fixed bit-rate HDMI. A MAT decoder was subsequently used in an AVR to unpack the Dolby TrueHD bitstreams. With the introduction of Dolby Atmos, we have expanded this technology to support encoding of Dolby Atmos content as lossless pulse-code modulation (PCM) audio.

A key benefit of Dolby MAT 2.0 is that Dolby Atmos object audio can be live encoded and transmitted from a source device with limited latency and processing complexity. Among the possible sources are broadcast set-top boxes and game consoles. The Dolby MAT 2.0 decoder in an AVR outputs the object-based audio and its metadata for further processing. The Dolby MAT 2.0 container is scalable and leverages the full potential of the HDMI audio pipeline.

Dolby Atmos object audio renderer

The Dolby Atmos object audio renderer is essentially the brain of a Dolby Atmos home theater. Dolby Atmos content consists of both sound objects and metadata that includes information about where those sounds should be placed and how they should move, along with other data such as the type of object represented. The Dolby Atmos object audio renderer knows the speakers available in your system (you'll supply this information by following the setup instructions provided by your AVR manufacturer) and determines which speakers to use from moment to moment to recreate the sound the filmmakers intended.

Depending on the receiver configurations, the Dolby Atmos object audio renderer can support as many as 34 speakers—24 traditional floor-standing speakers and 10 overhead or Dolby Atmos enabled speakers—along with one or more subwoofer(s). The renderer also supports smaller configurations, making it fully scalable and adaptable to a variety of home theaters.

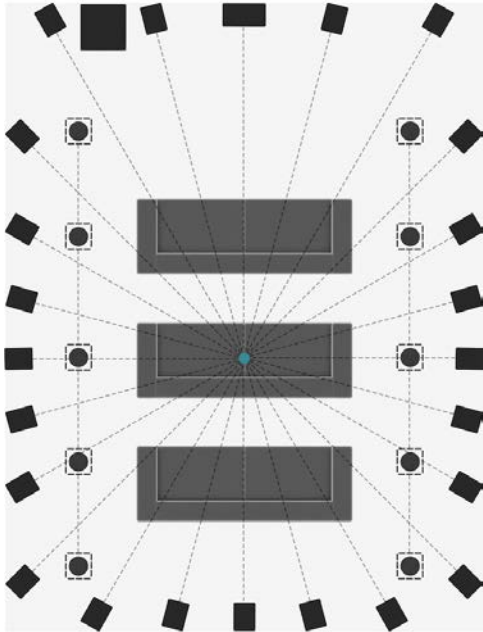

Figure 10: Dolby Atmos for home theaters supports as many as 24 speakers on the floor and 10 speakers producing overhead sound.

Dolby surround upmixer

If you invest in building a Dolby Atmos home theater, you want to get full use of it, even if the content you're playing isn't mixed in Dolby Atmos. That's where the Dolby surround upmixer comes in.

If you choose to enable it, the Dolby surround upmixer expands the audio of legacy channel-based content to take advantage of your entire system, including overhead or Dolby Atmos enabled speakers. The Dolby surround upmixer employs the original soundtrack to create a highly accurate rendering of the environment in the movie while simultaneously honoring and maintaining the artists' intent for the mix.

Unlike previous wideband upmixing technologies, the Dolby surround upmixer operates on multiple perceptually spaced frequency bands for a fine-grained analysis of the source signal. The Dolby surround upmixer can individually steer frequency bands, producing surround sound with precisely located audio elements and a spacious ambience. The Dolby surround upmixer is included in the Dolby Atmos technology bundle and replaces the Dolby Pro Logic II family of upmixers, offering greater flexibility and superior audio performance.

To maintain the frontal spatial audio image, the upmixer will not send upmixed audio to speakers that are located between the left, center, and right speakers or to the left and right wide speakers. Additionally, the unmixed audio is not sent to the center surround speaker. Spatial imaging is complemented through the use of overhead or Dolby Atmos enabled speakers in these cases.

Translating cinematic Dolby Atmos content to the home

As we've noted, Dolby Atmos allows each sound in a movie scene to be represented as a separate audio object. And each of these objects has its own metadata, describing precisely where it should originate and how it should move, among other data. This approach produces incredibly lifelike sound, but for a scene with lots of action, it also produces a lot of data. Getting all that data to your living room through the limited bandwidth of a Blu-ray Disc or streamed media pipeline is a challenge. We've met that challenge with a technology called spatial audio coding.

Spatial audio coding takes into account the spatial information, along with other information about the sound objects, to efficiently encode them in Dolby TrueHD and Dolby Digital Plus. Spatial coding is not a channel-based, matrix-encoding system like Dolby Pro Logic II or Dolby Pro Logic IIz. Instead, it is a fundamentally new coding technique that allows all of the original cinema audio objects to be sent to your home theater.

Filmmakers frequently remix a film to sound its best in home theaters, a process known as creating a near-field mix. Spatial audio coding is a tool available to sound professionals in the near-field mixing process. During playback, filmmakers can monitor exactly how the film will sound when it is encoded to Dolby Digital Plus for streaming or encoded losslessly in Dolby TrueHD for Blu-ray.

Creating Dolby Atmos soundtracks

Initial Dolby Atmos content for home theaters was delivered via Blu-ray Disc and streaming video via over-the-top (OTT) services. For Blu-ray, studios may employ lossless Dolby TrueHD for the primary soundtrack and Dolby Digital Plus for secondary languages. OTT services will be supported by Dolby Digital Plus. In the future, Dolby Atmos content will be delivered via video on demand (VOD), broadcast (terrestrial and digital), and cable services that use multichannel Dolby Digital Plus in their core architecture. Dolby Atmos can also be used in video game audio.

Production houses that create Dolby Atmos content for home theaters will use a tool called Dolby Media Producer, along with its suite of professional encoding, decoding, and media-related tools.

Before using Dolby Media Producer, though, production houses have the option to perform several preliminary steps, including a near-field remix and remastering of the cinematic master file. In this stage of the process, audio mixers may make small adjustments to the mix to ensure that it sounds as they intended in Dolby Atmos enabled home theaters.

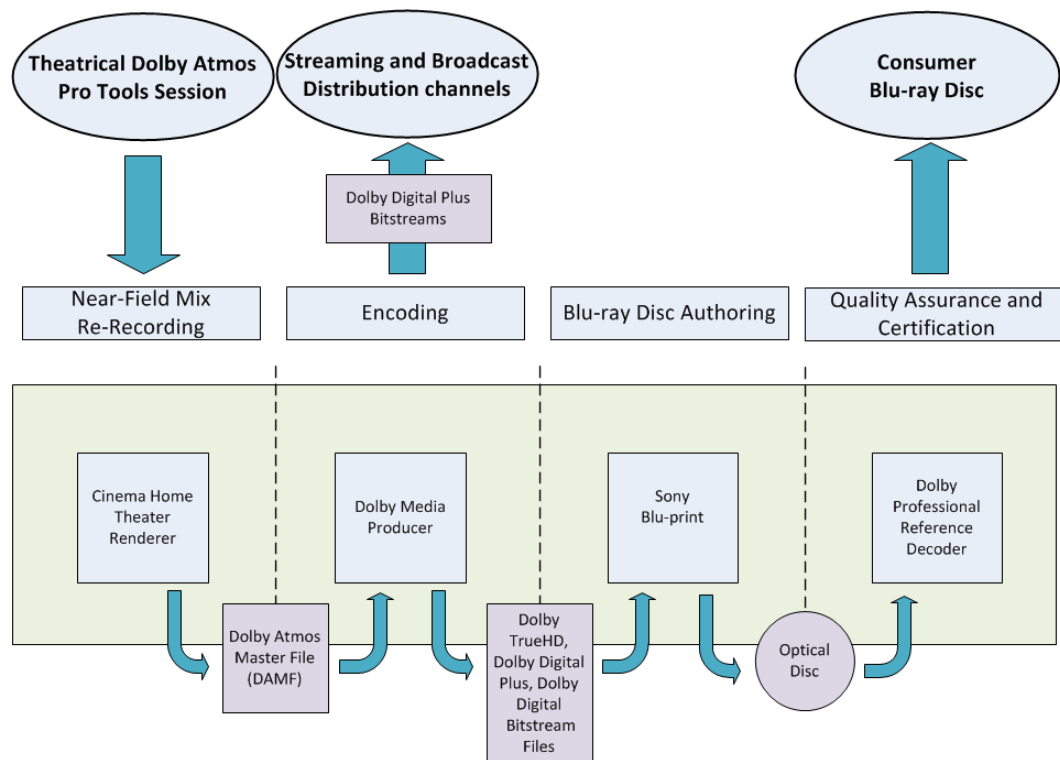

Figure 11: The content creation workflow for Dolby Atmos home content.

Conclusion

Dolby has invested years of engineering and research work into accurately translating the Dolby Atmos experience from the cinema to home theaters. Today we can bring a Dolby Atmos experience to the home through established delivery methods while maintaining backward compatibility with legacy playback systems. The result is nothing short of the most realistic and immersive entertainment experience ever available for home theaters.

The configurations noted herein are illustrative. We recommend that any overhead speaker installation be performed by professional installers with experience in installing overhead speakers.

Dolby, Dolby Atmos, Pro Logic, and the double-D symbol are registered trademarks of Dolby Laboratories. Dolby Digital Plus is a trademark of Dolby Laboratories. All other trademarks remain the property of their respective owners. © 2015 Dolby Laboratories, Inc. All rights reserved. S15/28307/28773