



Dolby Atmos<sup>®</sup> Enabled  
Speaker Technology

April 2015

## How to get Dolby Atmos sound with Dolby Atmos enabled speakers

Many leading Hollywood movies, including Academy Award® winners, are presented in Dolby Atmos®. This new sound technology allows filmmakers unprecedented realism and creative freedom when designing movie soundtracks. With Dolby Atmos, content creators can precisely place and move sounds almost anywhere, including overhead, to create a multidimensional listening experience.

This revolutionary experience is now available for your home and will produce audio like nothing you've ever heard in a home theater. And you'll get a great immersive entertainment experience no matter what kind of Dolby Atmos home theater setup you have, because the technology automatically adapts the sound to take full advantage of the number and placement of your speakers.

The dimension of height—hearing sounds coming from above you—is key to the Dolby Atmos experience. Reproducing overhead sounds requires new thinking about home theater design. In this white paper, we'll explain how you can use Dolby Atmos enabled speaker technology to build a system capable of reproducing overhead sound, even if you're not able to locate speakers overhead in your home theater.

### Do I have to replace all of my current speakers to build a Dolby Atmos system?

No. Many people now have 5.1 or 7.1 systems with a subwoofer and either five or seven speakers positioned at about ear level. Many of these speakers will work without a problem in a Dolby Atmos system.

However, overhead sound is a vital part of the Dolby Atmos experience. Many current home theaters aren't capable of producing overhead sound, but there are a number of options for adding this capability to any room.

### How do I get sound coming from above?

The obvious answer is to install speakers in the ceiling. Most conventional speakers designed specifically for high-quality music or movie reproduction mounted in or on your ceiling will work in a Dolby Atmos home theater.

But installing overhead speakers may not be possible or desirable for you. Installing speakers overhead and running the necessary wiring can be expensive and time consuming. If you rent your home, the property owner may not allow it. And if your ceiling is made of a material such as concrete, plaster, or brick, installing speakers in the ceiling is impossible. Finally, you may not like the look of overhead speakers.

### How can I get overhead sound if I don't mount speakers overhead?

Use Dolby Atmos enabled speakers. With a combination of unique physical speaker design and special signal processing, Dolby Atmos enabled speakers allow you to experience overhead sounds from speakers that are placed at the same level as traditional speakers. These new speakers direct sound upward to reflect off the ceiling, as Figure 1 shows, to create a faithful reproduction of audio coming from above.

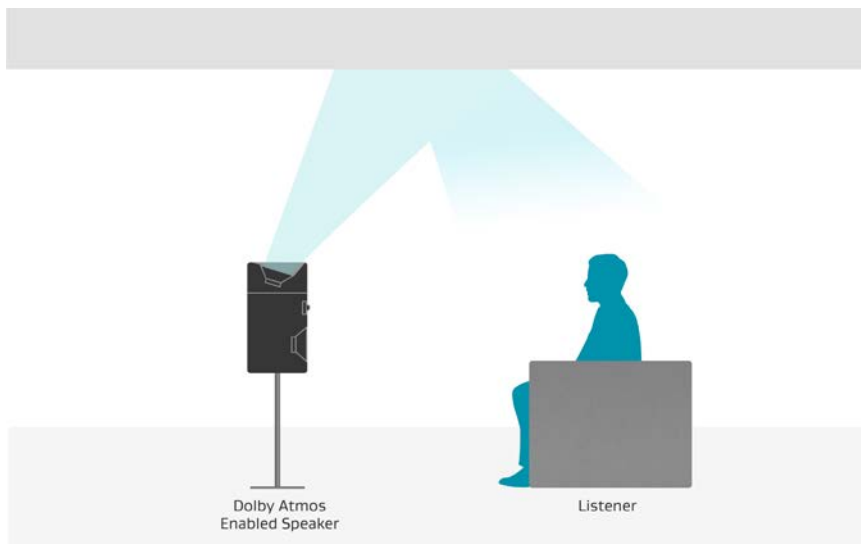

Figure 1: Dolby Atmos enabled speakers fire sound upward to reflect off the ceiling, creating exceptionally lifelike overhead sound.

You can purchase speakers that combine traditional design with the upward-firing Dolby Atmos enabled drivers in one cabinet. Or, if you don't want to replace your current speakers, you can purchase add-on speaker modules equipped with Dolby Atmos enabled speaker technology that you can place on top of or near your existing speakers.

## Will I always get better Dolby Atmos sound with overhead speakers?

Dolby Atmos enabled speakers produce slightly diffuse overhead audio that is quite lifelike and, in some cases, preferable to the sound that comes from overhead speakers.

If your ceiling is low or you have to mount your speakers on overhead trusses or brackets, the overhead speakers will be closer to the listening position. The audio may be distracting because you'll hear exactly which speaker is producing the sound instead of feeling immersed in an atmosphere in which sounds occur naturally overhead.

In this environment, Dolby Atmos enabled speakers may better reproduce the Dolby Atmos sound you would hear in a movie theatre, where the overhead speakers are high in the auditorium, creating a more diffuse experience. Audio experts who have heard Dolby Atmos enabled speakers agree that the sound these produce can be preferable to the sound that overhead speakers produce.

## How does Dolby Atmos enabled speaker technology work?

Dolby Atmos enabled speaker technology produces overhead sounds through a combination of psychoacoustic signal processing and proper direction and angling of the speaker drivers. Dolby provides requirements to manufacturers to ensure that their speakers will perform properly in a Dolby Atmos system for the home. But these requirements are flexible enough to allow manufacturers to maintain their sonic and industrial design.

Dolby Atmos enabled speakers do not rely on virtualized processing. That means you don't have to sit in a specific spot to get the full Dolby Atmos effect. The same signal and content from your receiver can go to either overhead speakers or Dolby Atmos enabled speakers. In fact, Dolby Atmos enabled speakers can also be combined with overhead speakers in a home theater environment.

Why would you combine overhead and Dolby Atmos enabled speakers? Perhaps you have two speakers already installed in your ceiling, but you want to add two more speakers that can produce overhead sound. You can add two Dolby Atmos enabled speakers and get detailed overhead sound without going to the trouble of installing new speakers in your ceiling.

You'll hear the same overhead sounds whether you're using overhead speakers, Dolby Atmos enabled speakers, or a combination.

Here are more details about the most important aspects of Dolby Atmos enabled technology.

### *Psychoacoustic signal processing*

Based on an understanding of how the brain interprets sound, Dolby Atmos enabled speakers modify select audio frequencies to reinforce the sense of sound coming from above.

### *Speaker directivity and angling*

Dolby Atmos enabled speakers are designed to fire their acoustic energy upward rather than directly at you. Dolby has calculated the best angle for the upward-firing element based on where most people place their floor-mounted tower and stand-mounted speakers and based on standard ceiling heights.

As a result, your brain experiences the sound coming from the reflection off the ceiling, rather than from the speaker itself. This works in combination with crossovers and bass management built into Dolby Atmos enabled speakers and A/V receivers (AVRs) to deliver a compelling and accurate overhead experience.

## **Will Dolby Atmos enabled speakers work in my room?**

Dolby Atmos enabled speakers can produce an incredibly immersive Dolby Atmos experience in many kinds of rooms. You'll get the best sound if your ceiling is flat (not vaulted or angled) and made of an acoustically reflective material, such as drywall, plaster, concrete, or wood. Dolby designed the technology for rooms with ceiling heights of 7.5 to 9 feet (2.3 to 2.7 meters), but testing has shown that you can still hear incredible overhead sound in rooms with ceilings as high as 14 feet (4.3 meters), though the effect may become more diffuse in rooms with higher ceilings.

Recessed lighting fixtures, chandeliers, crown molding, and heating or air conditioning vents in your ceiling do not noticeably interfere with the Dolby Atmos experience.

## What are the different types of Dolby Atmos enabled speakers?

There are two types of Dolby Atmos enabled speakers: integrated speakers and add-on speaker modules.

### *Integrated speakers*

Integrated speakers include a traditional front-firing speaker and a Dolby Atmos enabled speaker in the same speaker cabinet, as shown in Figure 2. The Dolby Atmos enabled speaker is housed in a separate sealed section of the speaker cabinet and has its own set of binding post inputs. Integrated speakers are great if you're considering purchasing new main or surround speakers.

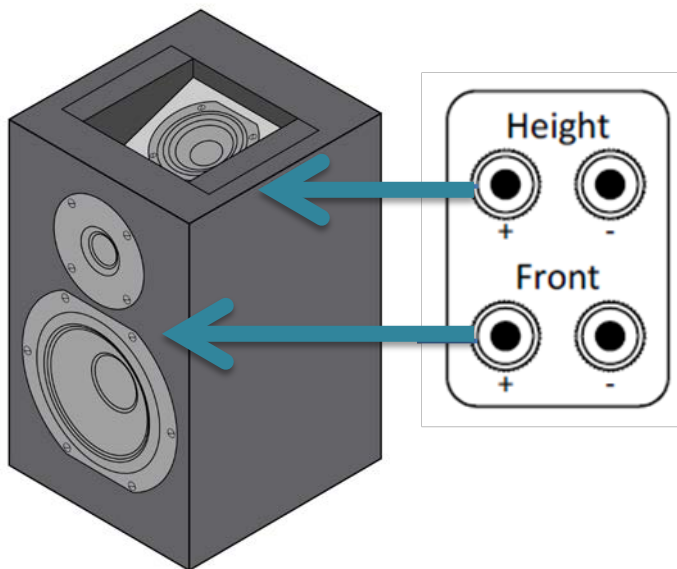

Figure 2: Dolby Atmos enabled integrated speakers include both traditional front-firing speakers and upward-firing elements. Both sets of speakers have their own binding posts to connect to two sets of terminals to your A/V receiver.

### *Add-on modules*

Manufacturers are also producing Dolby Atmos enabled speakers in separate cabinets, as shown in Figure 3. These are ideal if you already have primary speakers that you like. By adding separate Dolby Atmos enabled add-on modules, you can get a multidimensional Dolby Atmos experience while keeping your existing equipment. You can place the add-on modules on top of your existing speakers or nearby on another surface.

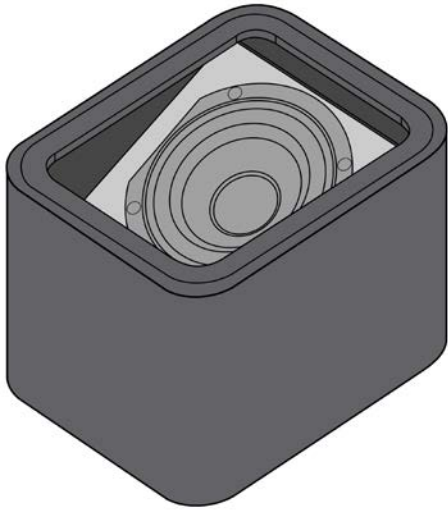

Figure 3: Dolby Atmos enabled add-on modules include only upward-firing elements. You can place them on top of your traditional, front-firing speakers or on another surface near them.

## How many Dolby Atmos enabled speakers do I need, and how should I set them up?

Dolby recommends that you use four Dolby Atmos enabled speakers when possible. Use of four speakers will make the placement of overhead sounds more accurate, and you'll get more precise, realistic sounds as an object—such as a helicopter—passes overhead in a video. Two of the speakers (whether they are integrated speakers or add-on modules) should be in the front left and front right speaker locations of your system. The other two should be positioned in the surround sound speaker locations, ideally the rear surround speakers, if you have them.

If you opt to use only two Dolby Atmos enabled speakers, you'll still get a very immersive experience, with sounds moving overhead. Place the Dolby Atmos enabled speakers at the front left and front right speaker locations.

For the best sound, place your speakers at or slightly above the level of your ears when you're seated. Don't place the Dolby Atmos enabled speakers higher than half the height of your wall. Make sure the speakers are at least 3 feet (0.9 meter) away from you, ideally 5 feet (1.5 meters) or more. If you're using add-on

modules, place them either on top of your front and surround (ideally, rear surround) speakers or within 3 feet (0.9 meter) of those speakers.

### How should I describe my setup?

With the debut of Dolby Atmos, there is a new way to refer to surround sound speaker configurations (see the “Dolby Atmos for the Home Theater” white paper for more details). It is based on the standard nomenclature (stereo, 5.1, and 7.1) but adds a number at the end to specify the number of height speakers you use (for example, 7.1.4).

Figures 4 through 6 show the most common speaker layouts in a Dolby Atmos system for home theater.

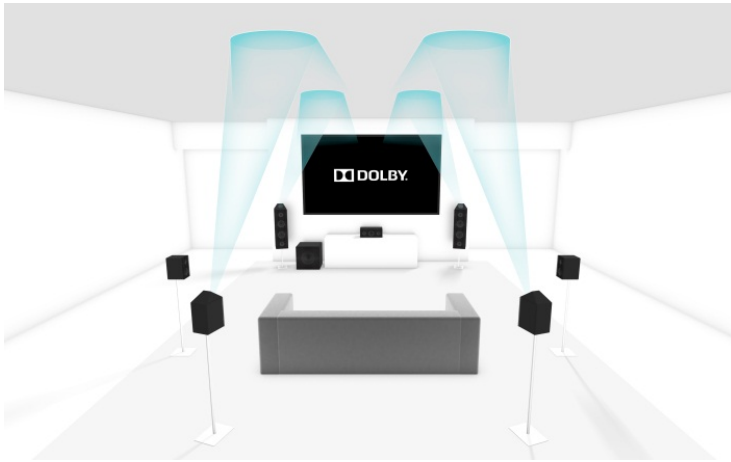

Figure 4: A traditional 7.1 speaker layout with four Dolby Atmos enabled speakers (7.1.4).

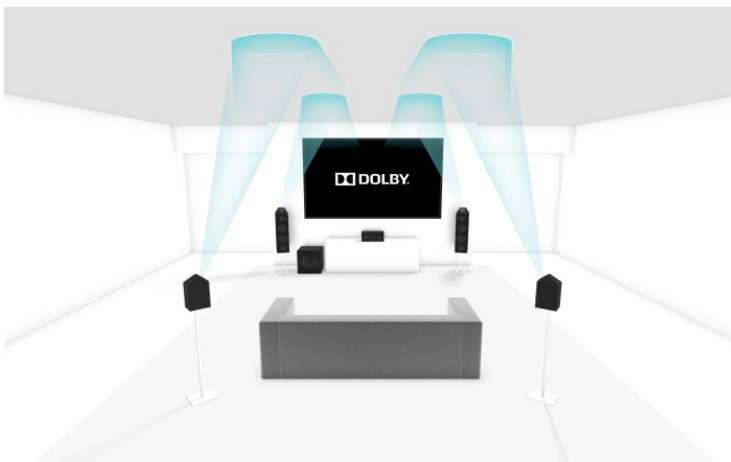

Figure 5: A traditional 5.1 speaker layout with four Dolby Atmos enabled speakers (5.1.4).





Figure 6: A traditional 5.1 speaker layout with two Dolby Atmos enabled speakers (5.1.2).

## How do I connect my Dolby Atmos enabled speakers to my AVR?

Many AVRs that support Dolby Atmos have speaker connections labeled HEIGHT, as in Figure 7. (Some AVRs do not use that label, but they allow you to assign terminals for the height outputs.) Connect your Dolby Atmos enabled speakers to those outputs. If you're using four Dolby Atmos enabled speakers (or think you might in the future), you need an AVR with four height outputs.



Figure 7: Rear panel of a 7.2.2 AVR; height speaker connections are at right.

## Conclusion

With Dolby Atmos enabled technology, you can get the overhead sound that is a cornerstone of the Dolby Atmos experience conveniently and efficiently, with products that complement your existing home theater system, look great, and won't break the bank. Dolby Atmos enabled speakers should be popular with many home entertainment enthusiasts because they provide the flexibility needed to create a Dolby Atmos system in virtually any home and for many different budgets.

*The configurations noted herein are illustrative. Dolby recommends that any overhead speaker installation be performed by professional installers with experience in installing overhead speakers.*

Dolby, Dolby Atmos, and the double-D symbol are registered trademarks of Dolby Laboratories.

Academy Awards is a trademark and service mark of the Academy of Motion Picture Arts and Sciences.

© 2015 Dolby Laboratories, Inc. All rights reserved. S15/28309/28781